

MODEL 5122A

ALIGNMENT SCOPE

INSTRUCTION MANUAL

KIKUSUI ELECTRONICS CORPORATION, JAPAN

78.6.11

781341

Power Requirements of this Product

Power requirements of this product have been changed and the relevant sections of the Operation Manual should be revised accordingly.

(Revision should be applied to items indicated by a check mark)

Input voltage

The input voltage of this product is _____ VAC,
and the voltage range is _____ to _____ VAC. Use the product within this range only.

Input fuse

The rating of this product's input fuse is _____ A, _____ VAC, and _____.

WARNING

- To avoid electrical shock, always disconnect the AC power cable or turn off the switch on the switchboard before attempting to check or replace the fuse.
- Use a fuse element having a shape, rating, and characteristics suitable for this product. The use of a fuse with a different rating or one that short circuits the fuse holder may result in fire, electric shock, or irreparable damage.

AC power cable

The product is provided with AC power cables described below. If the cable has no power plug, attach a power plug or crimp-style terminals to the cable in accordance with the wire colors specified in the drawing.

WARNING

- The attachment of a power plug or crimp-style terminals must be carried out by qualified personnel.

Without a power plug

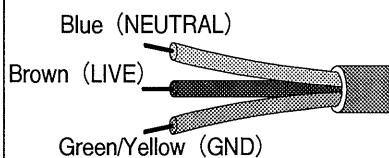

Without a power plug

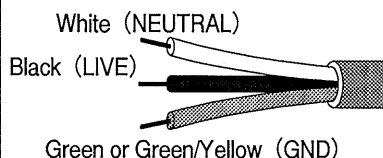

Plugs for USA

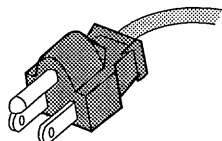

Plugs for Europe

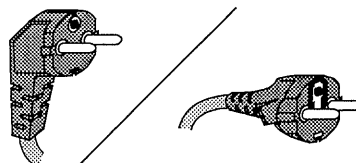

Provided by Kikusui agents

Kikusui agents can provide you with suitable AC power cable.
For further information, contact your Kikusui agent.

Another Cable _____

TABLE OF CONTENTS

	<u>PAGE</u>
1. GENERAL	1
2. SPECIFICATION	2
3. OPERATION METHOD	9
3.1 Explanation of Front Panel	11
3.2 Explanation of Rear Panel	14
3.3 Operating Procedure	16
3.4 Notes in Operation	21
4. CIRCUIT DESCRIPTION	23
5. MAINTENANCE	26
5.1 Adjustment of Trace/Graticule Parallelism	26
5.2 Internal Adjustments	27
5.3 AC Line Voltage Change	29
5.4 Components Layout	30
* Food Assembly	
* Block Diagram	
* Circuit Diagram	

781342

1. GENERAL

Kikusui Model 5122A Alignmentscope is a high-intensity dual-channel alignmentscope with a 12-inch electromagnetic deflection cathode-ray tube.

The vertical axis is sensitivity 1 mV/DIV, bandwidth 10 kHz; the horizontal axis is sensitivity 100 mV/DIV or over, bandwidth 1 kHz. Both axes are of DC coupling. An automatic spot killer circuit is incorporated to prevent CRT screen burning when no input signal is applied. A marker signal (a pulse marker signal or an intensity marker signal) can be externally applied.

The 5122A has dual-channel operation and AC clamp operation and other advantageous features. With its large CRT screen area, the 5122A can be effectively used as an adjusting instrument on a production line of TV or radio set as well as it can be flexibly used as a general purpose X-Y scope.

2. SPECIFICATIONS

CRT

Item	Spec.	Remarks
Type and size	Square type, 12 in.	
Fluorescent material	B4	White/black
Acceleration voltage	Approx. 6.3 kV	Regulated
Effective screen area	10 DIV x 14 DIV	1 DIV = 14 mm (0.55 in.)

Vertical Axis

Item	Spec.	Remarks
Sensitivity	1 mV, 10 mV, 100 mV, 1 V/DIV	4 ranges
Sensitivity accuracy	Better than $\pm 5\%$ of deflection amplitude on screen, with VARIABLE control set in CAL position.	At the center of screen, with amplitude of 5 DIV
Continuously-variable sensitivity adjustment	Continuously variable to 1/10 or more of panel-indicated value	Covering between ranges

798888
7813444

Item	Spec.	Remarks
Frequency bandwidth	DC: DC - 10 kHz AC: 3 Hz ~ 10 kHz	With 1 kHz 10 DIV as reference, within ± 3 dB
Input resistance	500 k Ω $\pm 30\%$	
Maximum allowable input voltage	100 V peak (DC + AC peak)	1 kHz or less for AC
Input coupling	AC, DC	Selectable with switch on panel
Polarity switching	Mutually independent switching for CH1 and CH2	180 ^o inversion
Operation modes of vertical axis	CH1: Independent operation CH2: Independent operation ALT: Dual-channel alternate operation	AC line frequency only
AC CLAMP	Applicable to sweep at AC line frequency (triangular wave or sine wave), only for a certain period of return trace.	Refer to Item 5 of Section 3.3.

781345

Item	Spec.	Remarks
Vertical axis linearity	Better than 5%	
Input terminal	BNC receptacle	

Horizontal Axis

Item	Spec.	Remarks
Sensitivity	100 mV/DIV or over	Non-calibrated
Continuously-variable sensitivity adjustment	Continuously variable to zero	
Frequency bandwidth	DC ~ 1 kHz	With 100 Hz 14 DIV as reference, within ± 3 dB
Input resistance	500 k Ω $\pm 30\%$	
Maximum allowable input voltage	100 V (DC + AC peak)	AC or less than 1 kHz
Input coupling system	DC	
Horizontal axis linearity	Better than $\pm 5\%$	

Item	Spec.	Remarks
Horizontal input mode	LINE SWEEP EXT SWEEP	Phase angle adjustable up to approx. 130°
Input terminal	BNC receptacle	

Marker Input

Pulse marker

Item	Spec.	Remarks
Sensitivity	1 DIV or over per 1 V p-p (minimum pulse width 20 μ sec, repe- tition period 250 μ sec)	Repetition frequency 15 kHz or less
Continuously-variable sensitivity adjust- ment	Continuously variable to zero	
Input resistance	100 k Ω \pm 30%	
Maximum allowable input voltage	50 V (DC + AC peak)	1 kHz or less for AC
Pulse polarity	Selectable for positive and negative	

781347

Item	Spec.	Remarks
Input terminal	BNC receptacle	In common for intensity modulation input terminal

Intensity Modulation

Item	Spec.	Remarks
Sensitivity	Modulation discernible with 1 V peak input (minimum pulse width 10 μ sec, repetition period 40 μ sec)	Frequency response: 1 kHz or less
Polarity	Intensity increases either with positive or negative polarity	Automatic switching
Maximum allowable input voltage	50 V (DC + AC peak)	1 kHz or less for AC
Input terminal	BNC receptacle	In common for pulse marker input terminal

7813481

Orthogonality and Deflection Distortion

Item	Spec.	Remarks
Orthogonality	Better than $90^{\circ} \pm 2^{\circ}$ at graticule center	
Deflection distortion	Better than 5% within graticule, for both vertical and horizontal axes	Including linearity

Power Supply

Item	Spec.	Remarks
AC input voltage	100/110/117V 220/230/240V	$\pm 10\%$
Frequency	50/60 Hz	
Power consumption	Approx. 50 VA	

781349

Dimensions and Weight

Item	Spec.	Remarks
External dimensions	430 W x 250 H x 350 D mm (16.9W x 9.84H x 13.8D in.)	
maximum dimensions	435 W x 265 H x 390 D mm (17.1W x 10.4H x 15.4D in.)	
Weight	Approx. 13 kg (28.7 lb.)	

Accessory

Instruction manual 1

Model 942A terminal adapter 2

179.8.28

781530A

3. OPERATION METHOD

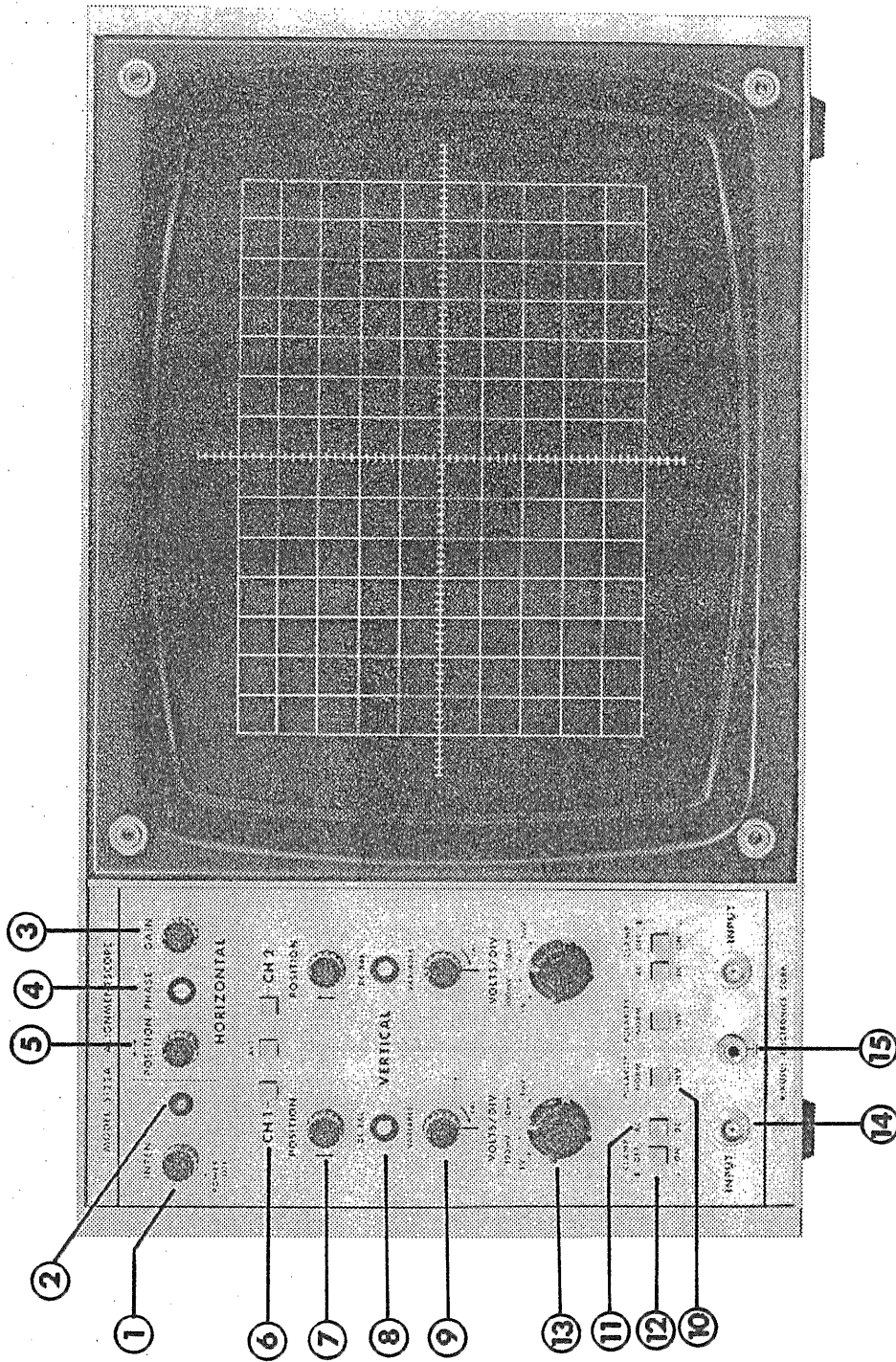

Fig. 3-1

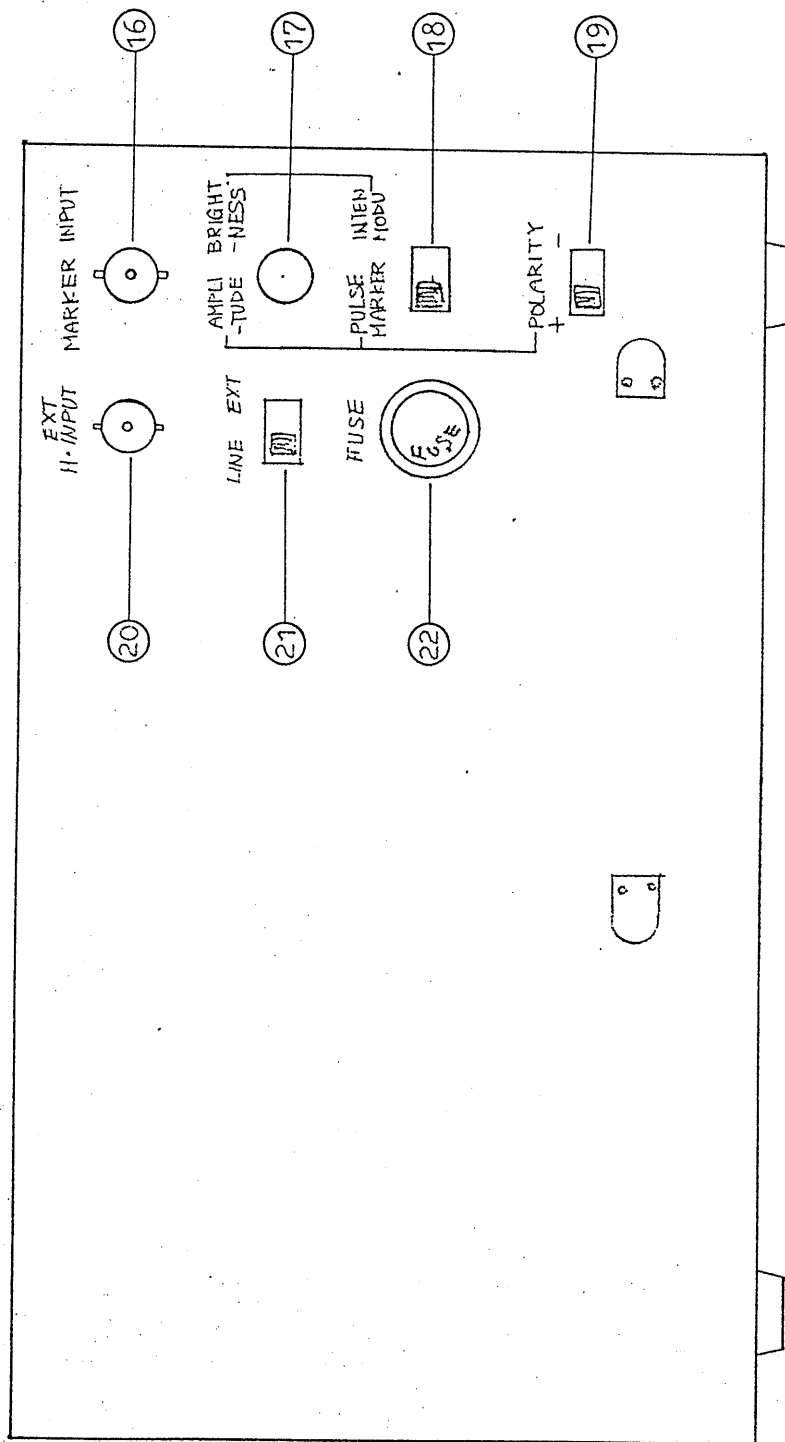



Fig. 3-2

781352

3.1 Explanation of Front Panel

- ① INTEN Intensity control with power switch. Intensity
POWER OFF increases as this knob is turned clockwise.
The extremely counterclockwise position is the
power OFF position.
- ②  Pilot lamp.
- ③ GAIN Horizontal axis adjustment knob. Continuously
variable to zero. Extremely clockwise position
is for highest sensitivity. Distortions are
caused if input voltage is larger than ± 6 V.
- ④ PHASE Phase adjustment of AC line sine wave.
This adjustment becomes effective when LINE/EXT
switch on rear panel is set in the LINE position.
- ⑤ POSITION Horizontal positioning knob of spot on CRT screen.

As you turn the knob clockwise, the spot moves
rightward, and vice versa.
- ⑥ CH1 The CH1 vertical axis alone operates, making the
instrument as a single-channel X-Y scope.
- ALT CH1 and CH2 vertical channels are swept alternately,
making the instrument as a dual-channel X-Y scope.

781353

CH2

The CH2 vertical axis alone operates, making the instrument as a single-channel X-Y scope.

⑦ POSITION



Vertical positioning knob of spot on CRT screen. As you turn the knob clockwise, the spot moves upward, and vice versa.

⑧ DC BAL

Semi-fixed resistor for DC balance. This resistor is so adjusted that the trace (base line) does not shift when sensitivity range is switched between 1 mV/DIV and 10 mV/DIV.

⑨ VARIABLE

Vertical sensitivity continuously-variable adjustment knob. The extremely clockwise position is the calibrated position (CAL position). By turning the knob counterclockwise, the sensitivity can be reduced to 1/10 or less of the panel-indicated range value.

⑩ POLARITY



Switch for inverting the polarity of vertical axis.



NORM

INV

The popped up state () is for the normal polarity and the depressed state () for the inverted polarity.



781354



⑪  AC
 DC

Switch for selecting the input coupling mode of vertical axis. The popped up state () is for AC coupling and the depressed state () for DC coupling. With AC coupling, the DC component of the input signal is blocked; with DC coupling, all components including DC are displayed on CRT screen.

⑫ CLAMP

Selects the vertical axis clamp action that, when the vertical axis input coupling is AC, the reference voltage for the displayed waveform is kept constant.

 OFF
 ON

The popped up state () is for clamp OFF and the depressed state () is for clamp ON. For the clamp operation, refer to Item 5 of Section 3.3.

⑬ VOLTS/DIV Vertical sensitivity selector.

⑭ INPUT

Vertical input terminal (BNC receptacle). The vertical input signal connected to this terminal is fed through AC/DC coupling selector switch and attenuator to vertical amplifier. The maximum allowable input voltage is 100 V peak.

⑮ 

Ground terminal.

3.2 Explanation of Rear Panel

①⑥ MARKER INPUT Marker signal input terminal (BNC receptacle).
Maximum allowable input voltage is 50 V peak.

①⑦ AMPLI- BRIGHT- Marker signal amplitude adjustment knob.
TUDE NESS Extremely clockwise position is for maximum
sensitivity. Continuously variable to zero.

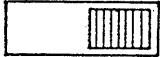
①⑧ PULSE INTEN Slide switch for selection between pulse
MARKER MODU marker and intensity modulation marker.
 Right hand position is for pulse marker and
left hand position for intensity modulation
marker.

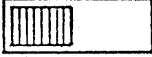
①⑨ POLARITY Pulse marker polarity selector for switching
+ - of marker polarity displayed on screen.
 Polarity "+" is for upward pulse on screen
with positive input pulse marker pulse, and
vice versa.

②⑩ EXT External horizontal input terminal (BNC
H INPUT receptacle). The input signal is through
the horizontal input selector switch to the
horizontal amplifier. The maximum allowable
input voltage is 100 V peak.

②1 LINE EXT



Horizontal input selector switch. When set in the LINE position, a reduced AC line signal is applied to horizontal axis; when in the EXT position, the signal fed to the EXT H·INPUT terminal is applied to the horizontal axis.

②2 FUSE

Fuse holder of instrument. Refer to section 5 "MAINTENANCE" for fuse rating.

3.3 Operating Procedure

1. Before turning-on the instrument power, adjust the control knobs as follows:

INTEN POWER OFF	Fully counterclockwise (POWER OFF)
GAIN (HOR)	Mid-position
↔ POSITION	Mid-position
CH1/ALT/CH2	Depress the ALT button.
↕ POSITION	Mid-position
VARIABLE	Fully counterclockwise
VOLTS/DIV	1 V/DIV
POLARITY	NORM
AC/DC	Either AC or DC
CLAMP	OFF
EXT/LINE	LINE (rear panel)

2. Turn the INTEN knob clockwise so that the instrument power is turned on and the POWER pilot lamp in the right-hand side of the knob turns on. The traces will be displaced on the screen in approximately 10 seconds. Adjust the INTEN and POSITION knobs so that the traces of an adequate intensity are displayed in appropriate positions.

3. When in the dual-channel operation, the switching points between CH1 and CH2 will be displayed as a vertical line. So adjust the PHASE control that the vertical line becomes the rightiest position of the traces.
4. Apply signals to the vertical input terminals and so adjust the VOLTS/DIV and VARIABLE knobs that the signals are displayed with appropriate amplitudes.
5. The AC CIAMP function of the instrument, in conjunction with a signal generator, is used for adjustment of pass bands and other characteristics of tuners and IF amplifiers of TV and radio sets. With this function, the return trace period of sweep can be held DC. Adjustment becomes very convenient as one end of the waveform displayed on the CRT screen is fixed.

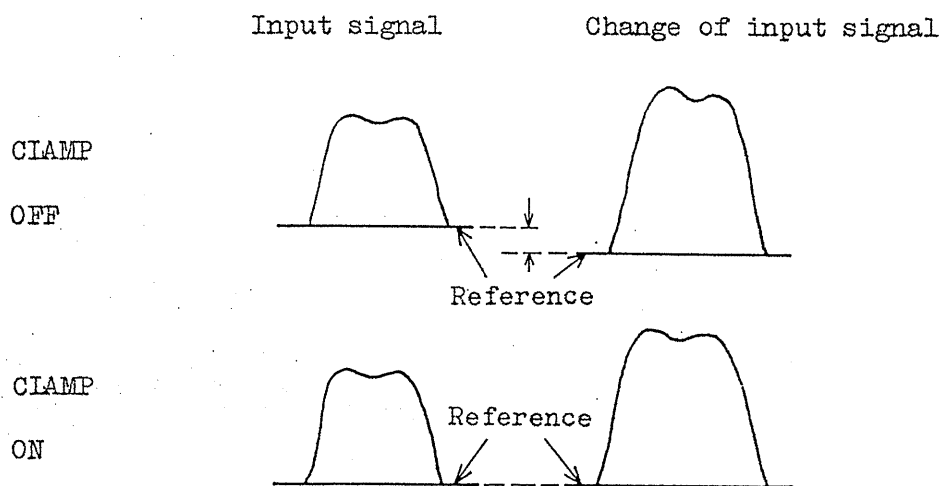

Fig. 3-3

If the clamp circuit is OFF, when the input signal has varied, the displayed waveform will shift upward or downward and a certain period will be required before stabilization; if the clamp circuit is ON, the reference point is fixed and the waveform is stabilized constantly, as shown in Fig. 3-3.

When the clamp operation is required, pay attention to synchronization of vertical and horizontal input signals.

The actions of Items (1) through (4) as following are illustrated in Fig. 3.4 ~ Fig. 3-6.

- (1) When the sweep frequency is 50 Hz and the sweeps are with return periods, the CH1, CH2 and ALT operations are possible as shown in Fig. 3-4 and the clamp function is effective for each operation.
- (2) When the sweep frequency is 50 Hz and the sweeps are without return periods, although the CH1, CH2 and ALT operations are possible as shown in Fig. 3-5, the clamp function is ineffective as there exist signals during periods in which the clamp function is to be effected. Therefore, stop the sweep generator output for the return periods.
- (3) When the sweep frequency is 25 Hz, the clamp function is ineffective as shown in Fig. 3-6.

- (4) Only when the sweep signal is a 50-Hz sine or triangular wave, both dual-channel operation and clamp function are possible at the same time. With such a signal as a sawtooth wave, it is impossible to attain the dual-channel operation and clamp function at the same time.

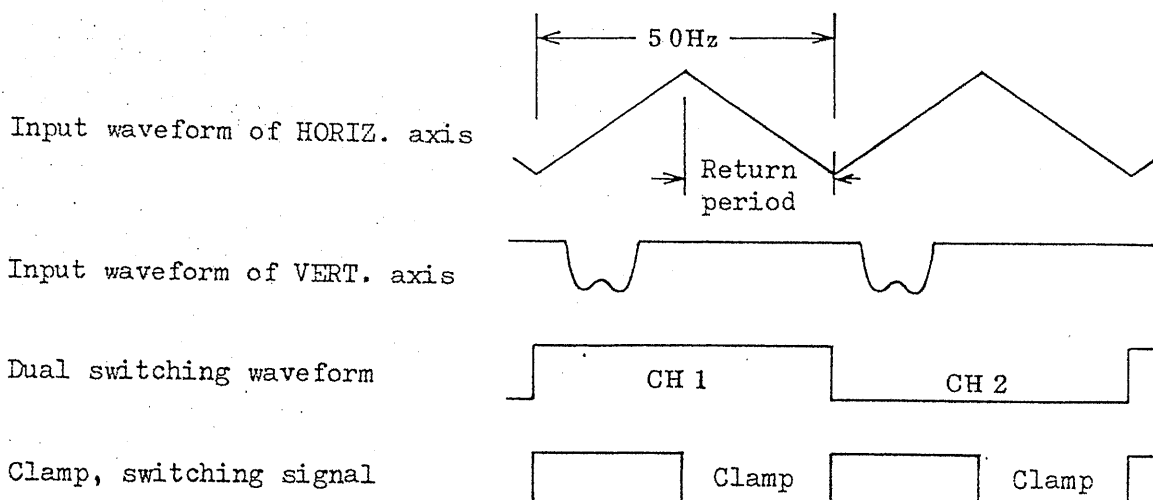

Fig. 3-4

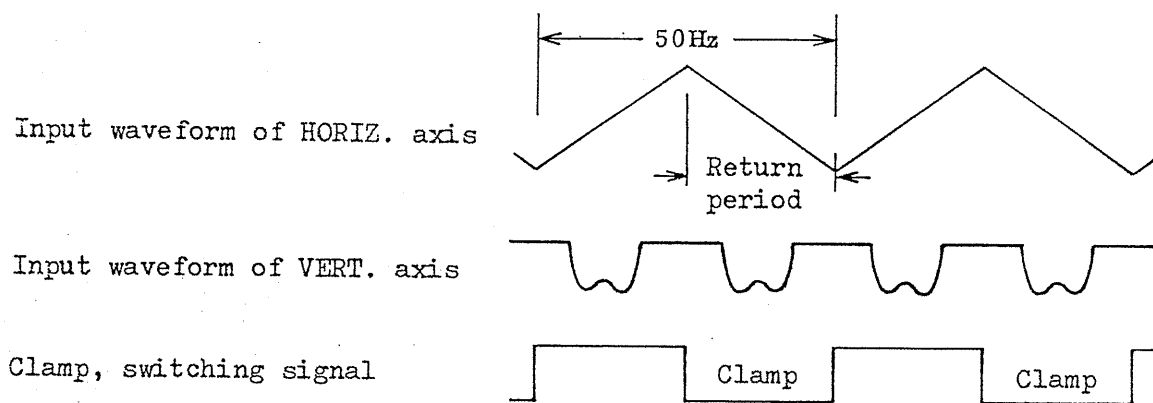

Fig. 3-5

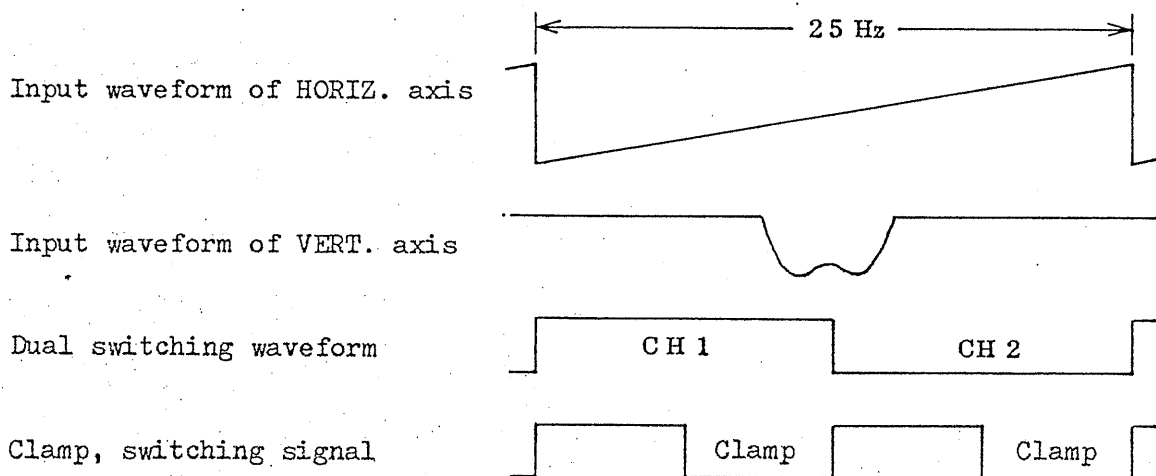

Fig. 3-6

3.4 Notes in Operation

1. If the horizontal base line does not conform with the graticule line due to terrestrial magnetism or other external cause, loosen the clamping-screw of the deflection yoke and so rotate the yoke that the lines are made parallel with the graticule line.
2. An automatic spot killer circuit is incorporated in order to prevent CRT screen burning when the spot is stationary. However, if the intensity knob is set deeply in a clockwise position, the spot appears on the screen overcoming the effect of the spot killer circuit. Do not leave the instrument in this state for a long time -- turn the intensity knob to a point where the spot disappears from the screen.

The CRT screen may be damaged (burnt) if the horizontal input is reduced to zero (the horizontal input is disconnected) while the instrument is operating with the maximum intensity without vertical input or if the sensitivity is reduced to zero. When there is a possibility of causing the above state, reduce the intensity beforehand.

3. The extremely clockwise position of the vertical sensitivity knob is the calibrated position.
4. The maximum allowable input voltage of the vertical axis is 100 V (DC component + AC component peak).

5. This strument can be converted to 100 V, 110 V, 117 V, 220 V, 230 V, or 240 V by means of the transformer taps. (Refer to Item 5.3 of Section 5 "Maintenance").
6. The ambient temperature range for satisfying the specification performance is 5°C to 35°C (41°F to 95°F).
7. The ALTERNATE operation and CLAMP function are possible when the horizontal axis input signal is of the AC line frequency and of a sine wave or triangular wave. For the operation method, refer to Item 5 of Section 3.3 "Operation Procedure".

179.8.28

781364A

4. CIRCUIT DESCRIPTION

Refer to the attached block diagram and schematic diagram.

1. Vertical Axis

The vertical input signal is fed through AC/DC selector switch (SW101, 201) and attenuator (SW102, 202, R104, 205) to the vertical amplifier. The vertical amplifier is a differential amplifier and its gain is adjustable with semi-fixed resistors (R112, 120, 221, 223). The current of the final stage is controlled at approximately 300 mA with semi-fixed resistor (R006).

The CLAMP circuit provides a negative feedback circuit for the vertical amplifier. The feedback signal is connected to one of the inputs of the differential amplifier through the switch (SW104, 204) in order to fix the reference signal for the input signal.

2. Horizontal Axis

The horizontal input signal is fed through selector switch (SW501) and attenuator (R503) to the amplifier. The gain is set with fixed resistors. Non-linearity of horizontal deflection is compensated for with a varistor and a semi-fixed resistor (R519).

The current of the final state is controlled at approximately 180 mA with semi-fixed resistor (R516).

3. Gate Signal Circuit

The gate signal for the clamp circuit is produced by converting the waveform of the secondary output of the power transformer using a Schmitt circuit. The signal is fed through the frequency divider circuit to the dual-channel switching circuit.

4. Spot Killer Circuit

Part of the horizontal amplifier output is detected and the detected signal is applied to No. 1 grid of the CRT in order to cut off the electron beam. Note that the spot may appear on the CRT screen despite the spot killer circuit is operating, if the INTENSITY knob is set deeply in a clockwise position. (Refer to 3.4 "Notes in Operation".)

5. Pulse Marker

The pulse marker signal is applied through the marker attenuator (R351) to the vertical amplifier. The polarity of the marker displayed on the screen can be inverted by means of the pulse marker POLARITY switch.

6. Intensity Modulation Marker

The intensity modulation marker signal is applied through the marker attenuator (R351) and amplifier to the CRT cathode.

The displayed trace is automatically intensity modulated either with a positive or negative marker signal.

7. Power Supply Circuit

The secondary power of the transformer is rectified with CR401 ~ 404 and regulated into the +15V and -15V supply voltages.

8. High Voltage Circuit.

The high voltage generator in the high voltage unit oscillates at a frequency of approximately 45 kHz. The oscillated power is boosted with a transformer and rectified into a DC acceleration voltage of approximately 6.3 kV for the CRT.

5. MAINTENANCE

5.1 Adjustment of Trace/Graticule Parallelism

Set the horizontal axis input selector switch in the LINE state and display the horizontal trace without applying any signal to the input terminal. If the displayed trace line is not parallel with the graticule center line, proceed as follows.

- (1) Remove the clamping-screws of the casing and pull out the instrument chassis.
- (2) Loosen the clamping-screw of the deflection yoke at the CRT neck, and so rotate the yoke that the base trace line is made parallel with the horizontal graticule line.
- (3) Tighten the clamping-screw, with the deflection yoke being pressed toward the CRT screen as far as it goes.

Precautions:

- 1) Note that the high acceleration voltage is being applied to the CRT.
- 2) Do not disturb the set states of the deflection yoke centering and compensation magnet.

781368

- 3) Pay attention so that no large vibration or shock is applied to the CRT neck.

5.2 Internal Adjustment

For inspection and adjustment of the internal circuits of the instrument, refer to the components layout diagram. The instrument has been critically adjusted at the manufacturer's factory. No internal circuit adjustment is required unless a circuit has become malfunctioning or a component has been replaced.

- (1) Check of supply voltages

Check that the voltage of pin 6 of the PCB connector is $-15\text{ V} \pm 0.5\text{ V}$ and that of pin 7 is $+15\text{ V} \pm 0.5\text{ V}$.

- (2) HOR BIAS ADJ (R516)

For current control of final stage of horizontal amplifier and for linearity compensation. Controls the final stage transistor current at approximately 180 mA for positioning the spot at the center of horizontal line.

- (3) LINEARITY ADJ (R519)

For linearity adjustment of horizontal deflection (for compensation of linearity of trace displayed on CRT screen).

(4) VERT BIAS ADJ (R306)

For current control of final stage of vertical amplifier and for linearity compensation. Controls the final stage transistor current at approximately 300 mA for positioning the spot at the center of vertical line.

(5) VERT GAIN ADJ

For sensitivity adjustments of CH1 and CH2, mutually independently. For adjustment of the 10mV/DIV range, set the VARIABLE knob in the CAL position and adjust the GAIN control (R120, R221). For adjustment of the 1mV/DIV range, set the VARIABLE knob in the CAL position and adjust the GAIN control (R122, R223).

When adjusting both 10mV/DIV and 1mV/DIV ranges, be sure to adjust the 10mV/DIV range at first.

(6) DC BAL ADJ

Set the ^DC BAL knob of the front panel in a mid-position of its adjusting range, and so adjust the semi-fixed resistor (R107, R208) that the trace base line does not shift when the sensitivity is switched between 10mV/DIV and 1mV/DIV ranges.

781370

5.3 AC Line Voltage Change

The Alignment scope is shipped from the manufacturer's factory being set for AC line voltage of 100 V ± 10 V AC. To convert it for other AC line voltage of 110 V, 117 V, 220 V, 230 V, or 240 V $\pm 10\%$, change the transformer primary circuit taps referring to Fig. 5-1.

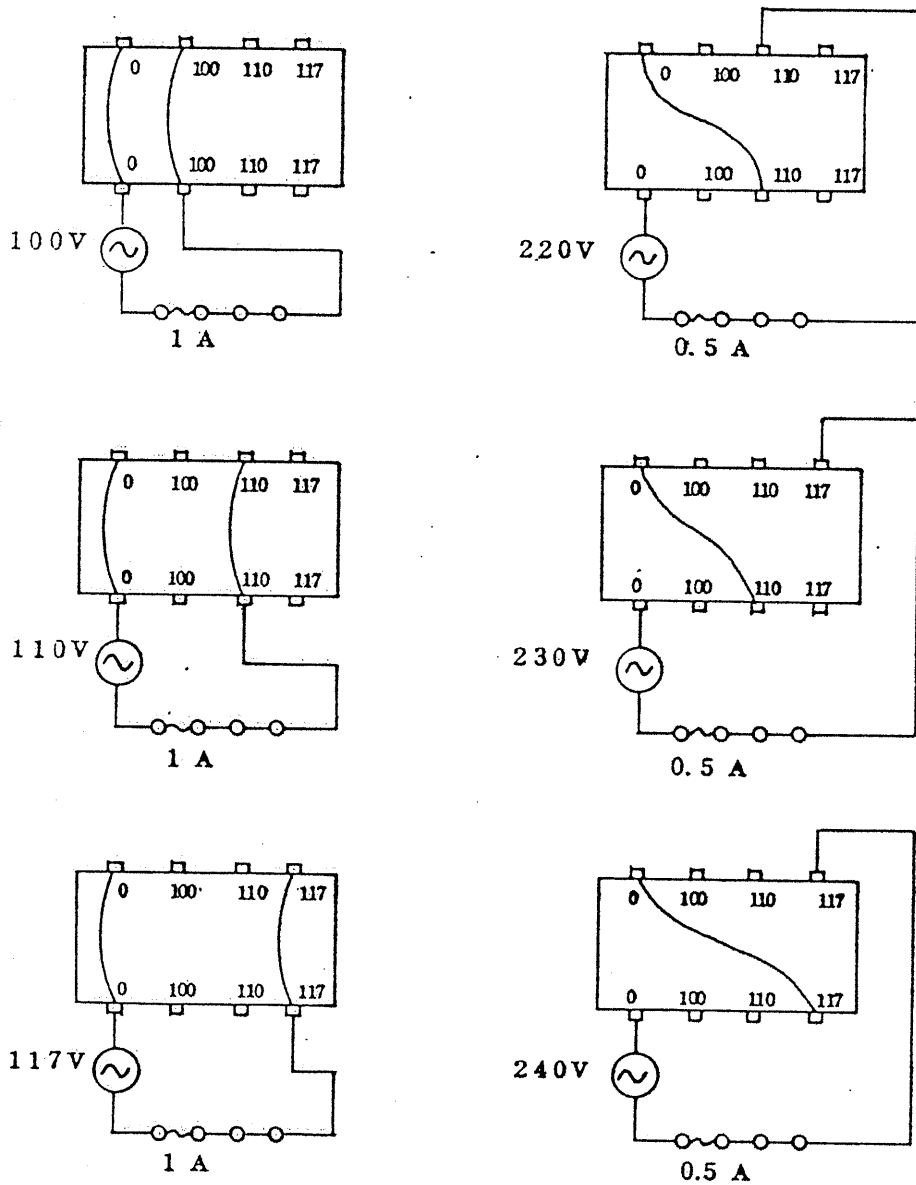
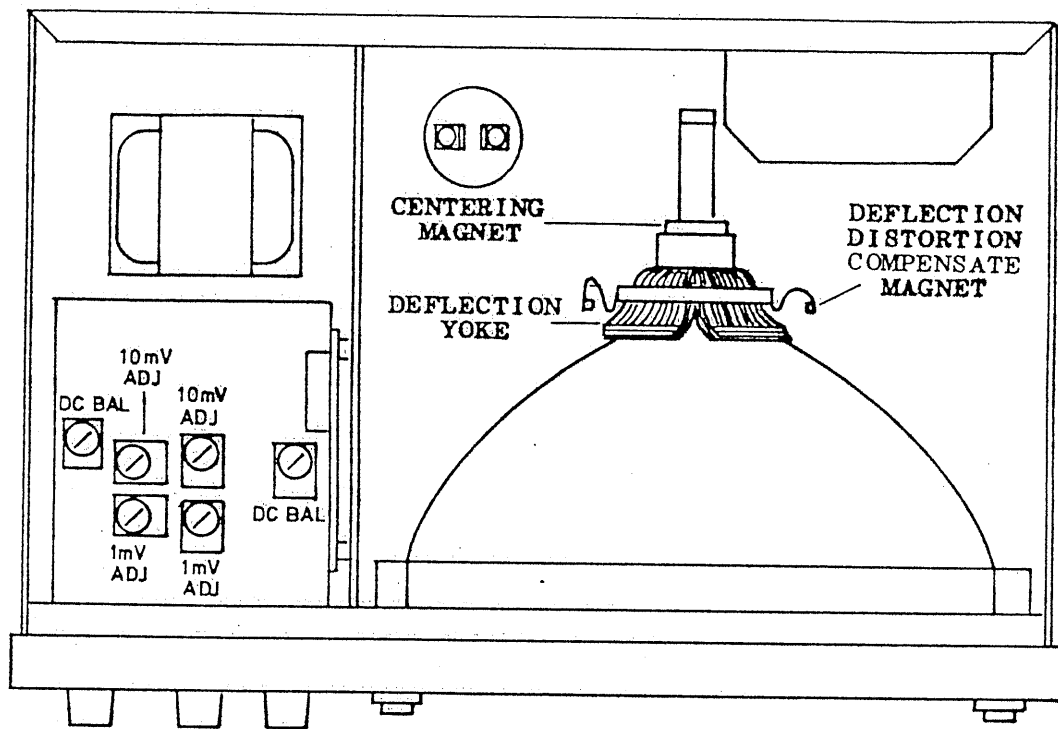

Fig. 5-1 Transformer tap connections for different AC line voltages

781371

5.4 Components Layout

TOP VIEW



LEFT SIDE VIEW

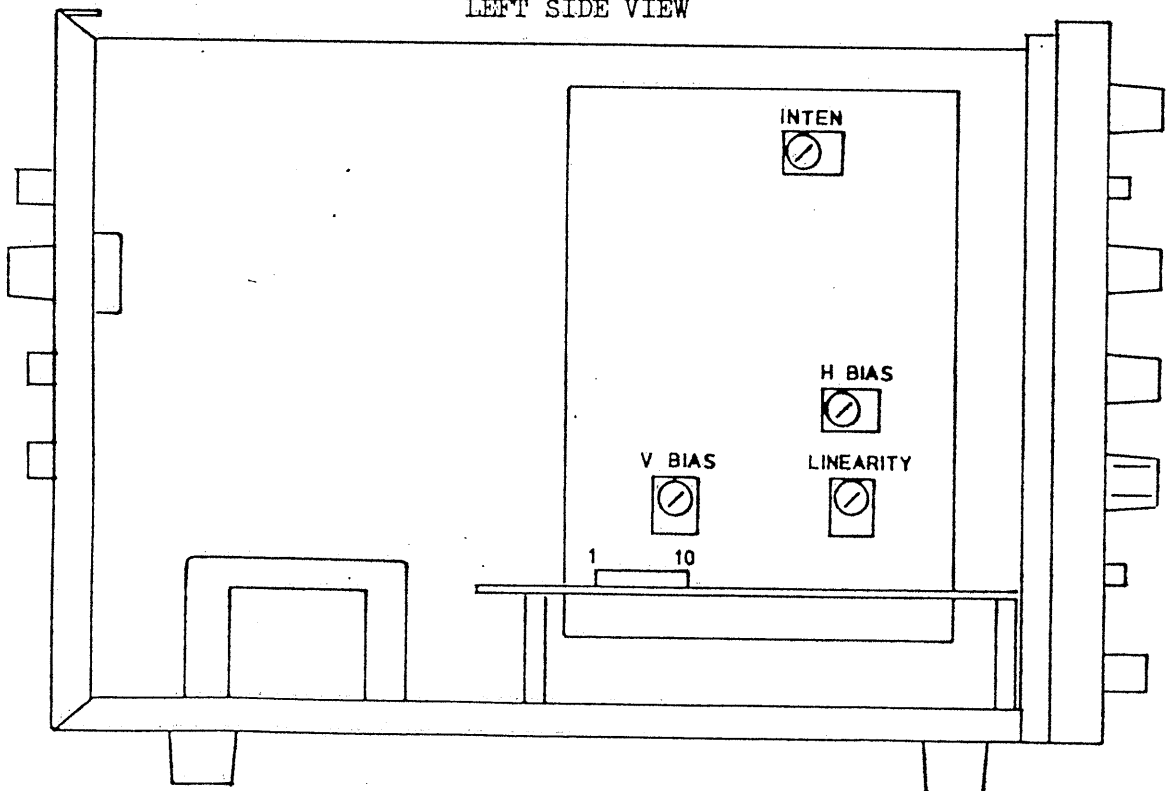

Fig. 5-2

781372

Hood Assembly

The hood which is OPTION of the Model 5122A is used to shield the CRT screen against light incident from above.

Refer to the bellow illustration to assemble the hood.

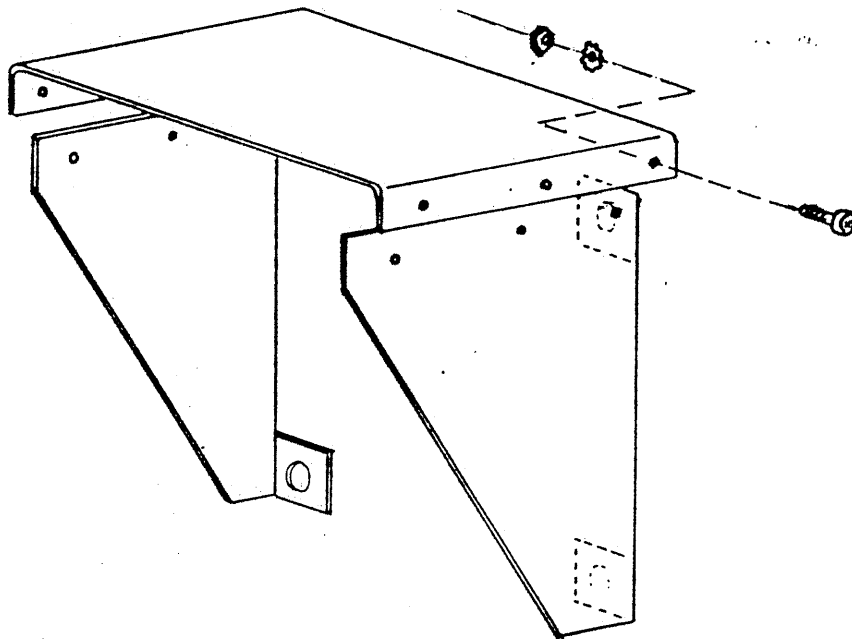

781373

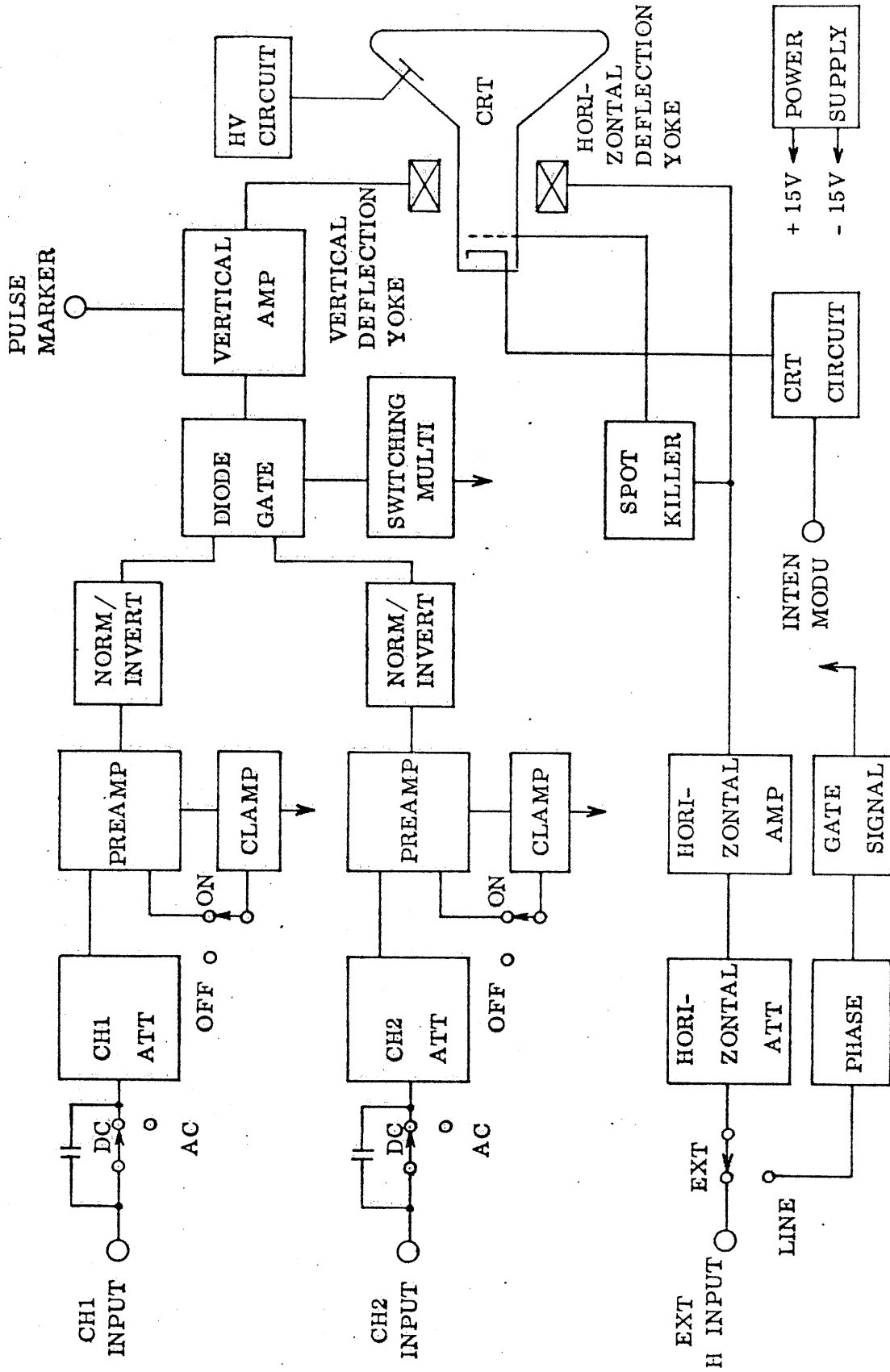

Block Diagram

761374